



PRESSMATE CONTROLLER

SERVICE MANUAL

For Use By Authorised Service Agents

Models covered by this manual:

SL100A1—Single Phase 2.2kW Motor

SL100A3— Three Phase 2.2kW Motor

SL200-Three Phase 4kW Motor

SL400-Three Phase 5.5.kW Motor

27 Young Street
Deepwater. N.S.W. 2371
Australia.
Phone: (02) 67 345 262
Fax: (02) 67 345 020
www.starlogixs.com.au

NOTES

CONTENTS

Owners Manual	
Introduction_____	4
Important Safety Notice_____	5
Location of Controls and Switches_____	6
Basic Operating Procedures_____	7
Motor Operation_____	8
Optional Extras_____	8
Basic Servicing_____	9
Copyright_____	10
Specifications_____	10
Warranty_____	11
Service Manual	
The Hydraulic Pressure Switch_____	12
The Full Bale Switch_____	13
The Infra-Red Detection System_____	14
The Hydraulic Valve Energisation Method_____	14
Machine Protection Features in Controller_____	15
Controller Active LED_____	16
Electric Motor Control_____	16
Options Plug Loop-Back_____	16
Trouble-shooting	
No Power_____	17
Baler Won't Cycle_____	18-19
Baler Continually Cycles_____	20
Baler Won't Eject_____	21
Main Wiring Diagram_____	22
Connector Pin-Out_____	23
Motor Contactor And Overload Relay Details_____	24
Spare Parts Lists_____	25
Distributor Lists_____	26
Procedure to Change Power Blocks_____	29
Procedure to Change Interlocked Door Switch_____	30
Procedure to Change PCB_____	31
Set-Up Tactile Switches in Relation to Touch-Pad_____	33
Category III Safety Changes_____	34
Category III Wiring Diagram_____	35
Critical Safety Components_____	36

OWNERS MANUAL

Thankyou

For choosing a Starlogixs PressMate Controller.

For operating this Controller properly, please take some time to read this owners manual thoroughly before starting operation of your Autobaler.

Keep this manual handy for future reference.



CAUTION

IMPORTANT NOTICE

Should you leave your Autobaler unattended for a period of time, it is strongly recommended that you switch the power off and remove the key.

IMPORTANT SAFETY NOTICE



IMPORTANT NOTICE

Should you leave your Autobaler unattended for a period of time, it is strongly recommended that you switch the power off and remove the key.

- ? The StarLogixs PressMate Controller provides vital safety features in your press. If the Controller has been damaged always have it checked by an approved service agent before operating the press.
- ? Check all power leads and plugs for damage. If damage is found switch off and disconnect from supply, and have repaired by an approved service agent.
- ? The 'door closed' sensors are critical to the safe operation of the press. If they are damaged or the mechanism driving them is damaged never attempt to use the press before calling an approved service agent.
- ? **The Controller has lethal voltages inside.**
- ? **Never open** or attempt to service.
- ? **Never remove** or attempt to remove the back cover.
- ? **No user serviceable parts** or adjustments inside.
- ? **Do not directly expose** Controller to rain or high pressure water jets.

LOCATION OF CONTROLS AND SWITCHES

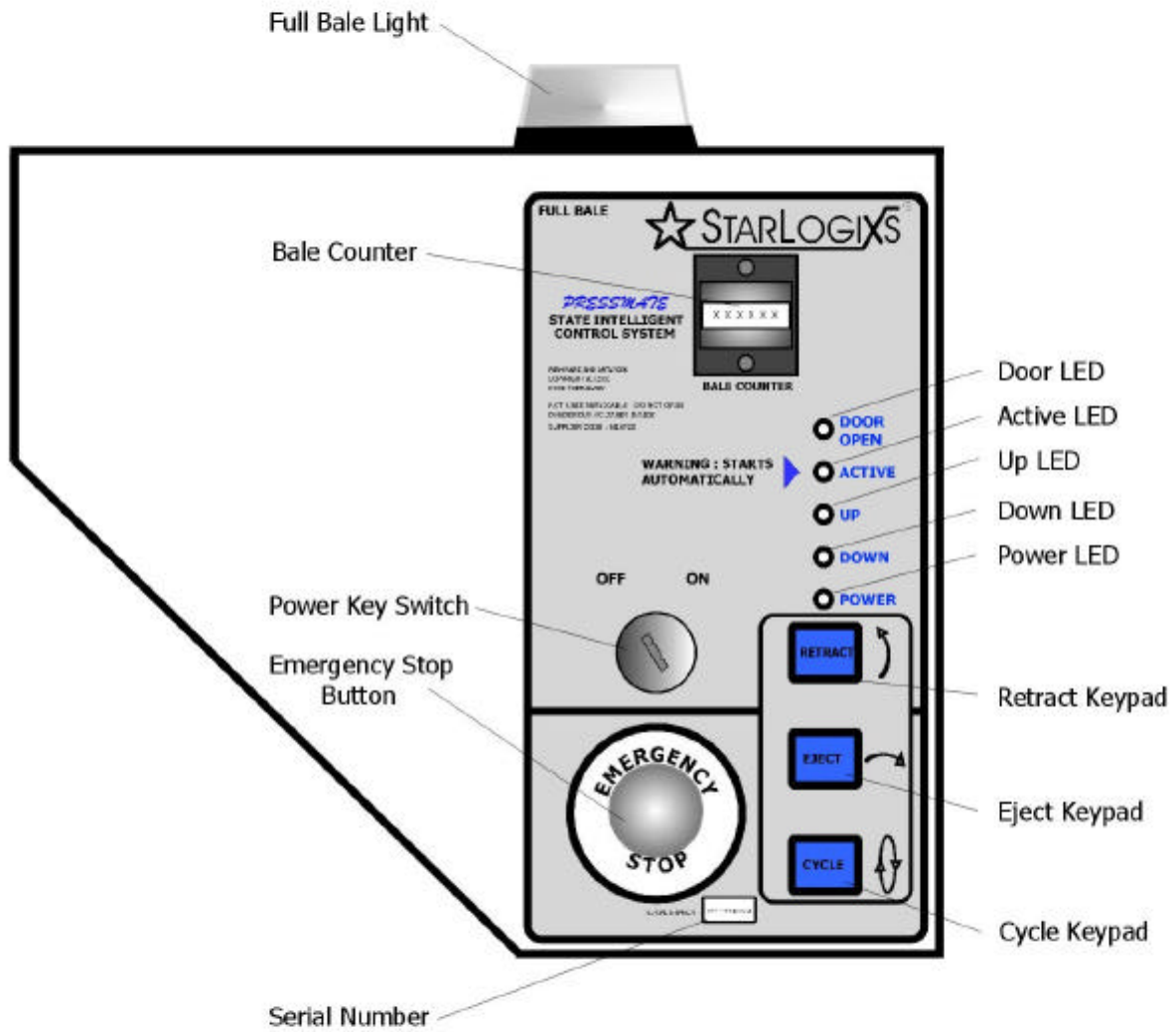

BASIC OPERATING PROCEDURES



IMPORTANT

Read this procedure in conjunction with procedures in your press manual.

1. Switch on Power Key Switch and check that Emergency Stop Button is not depressed (rotate to release). The Power LED should illuminate.
2. Close press doors. If door is not properly shut the Door LED will remain illuminated and the only function that will work is the bale eject.
3. Press Retract Keypad and the Up LED will illuminate, the electric motor will start, and after a 4 second delay the pressing fingers will move upwards to their retracted position and stay there.
4. After filling pressing compartment and hopper with material, press the Cycle Keypad. The Active LED will commence flashing indicating the press has entered its automatic mode. The Down LED will illuminate and the pressing fingers will move downward compressing material. If the Infra-red sensors detect material in the press hopper the machine will automatically cycle until the hopper is cleared. Alternatively the operator can manually initiate another cycle by pressing the Cycle Keypad.
5. The press will continue to operate automatically until a full bale condition is detected. The last pressing cycle is completed and an audible beeper and the full bale light are activated! The Infra-Red sensors will stop causing the press to cycle, but the operator can cause further cycles by pressing the Cycle Keypad. This allows material already in the hopper to be compressed.
6. After tying-off the bale (see press manual) the top press door must be shut. Pressing the Retract Keypad will cause Up LED to illuminate and the pressing fingers to move upwards to their retracted position, and stay there. If this does not occur check door is shut properly (Door LED should not be illuminated.)

NOTE: To guard against accidental operation the keypad must be pressed and held for about **1 second** before the Controller responds.

MOTOR OPERATION

The PressMate Controller intelligently controls the electric motor for maximum energy efficiency. If the press completes an operation and no new functions are required in the next 16 seconds the motor is stopped.

If the motor has stopped and a press function is required the motor automatically starts, but press functions are suspended for 4 seconds allowing the motor to start under no load and stabilise at its running speed.

OPTIONAL EXTRAS

The StarLogixs PressMate Controller is supplied with an options connector, which has a loop-back plug fitted. If this plug is removed an option kit must be fitted or the controller will not function.

Two option kits are available:

Remote Control Kit

This kit allows the machine to be operated from a remote operator panel and provides Cycle, Eject, Retract keys.

In addition it allows for monitoring of a secondary safety door or device, and also provides a full bale light.

The standard kit provides 5 meters (15 feet) of cable between the PressMate Controller and the remote operator panel. For more details contact your local sales agent.

Auxiliary Control Kit

Your StarLogixs Controller has an auxiliary relay fitted, which changes state when a full bale is detected. This can be used for simple control of external devices like cardboard conveyor, systems in assembly line.

In addition 24Vac lines are available, thus providing all necessary requirements for driving motor contactors. Always consult your local sales agent before implementing this option because incorrectly rated loads could seriously damage your Controller.

BASIC SERVICING

The StarLogixs PressMate Controller is a state of the art electronic control system that is designed for long service free life.

No part of the controller is serviceable, and should never be opened because there are **dangerous voltages** inside.

However, some basic service can be performed by the operator, as detailed below :

1. No Power

- ? Check that the mains outlet is working properly. Test by plugging another machine into the outlet. If there is a fault with the outlet call a qualified electrician.

Never try to make repairs to mains equipment.

- ? Check the fuse located on the bottom of the Controller. If it is blown only replace with a 4A MGC glass fuse. Use of an incorrect fuse may result in serious damage to the Controller, and will void your warranty.

- ? If the fuse continuously blows call for service.

2. Press Continually Cycles

- ? Sometimes material in the pressing hopper can stick to the lens surface of the Infra-Red detector. Clean lens with a soft cloth dampened with water and a mild detergent.

- ? Never use abrasive pads or harsh chemicals on the lens.

3. Electric Motor Cuts Out

- ? Your StarLogixs Controller is fitted with a thermal overload relay to protect the electric motor. This unit is an auto-resetting type, and will reset after about 1 minute. If the motor continually cuts-out there is a fault and you should call for service.

COPYRIGHT

Copyright 2001 by StarLogixs Pty. Ltd.

All rights reserved. The contents of this document, Controller front panel artwork, printed circuit board artwork, and firmware (programs contained in Controller integrated circuits) are subject to copyright and can not be reproduced, transmitted transcribed, stored in a retrieval system, or translated into any language or computer language, in any form or any means, electronic, mechanical, magnetic, optical, chemical, manual, or otherwise, without prior written consent from StarLogixs Pty. Ltd.

SPECIFICATIONS

Power Supply: 415V ac 50Hz 20A
: (240Vac 50Hz 20A for SL100A1)

Control & Sensor Power Supply: 24Vdc fully mains isolated.

Motor Rating: SL100A1-2.2kW Single Phase
SL100A3-2.2kW Three Phase
SL200- 4kW Three Phase
SL400- 5.5 kW Three Phase

Motor Protection: Auto resetting thermal overload relay.

Panel Fuse: 4A MGC 32mm Glass Type.

Hopper Detection System: Infra Red encoded beam type.

Door Closed Detection: Mechanical limit switch and interlocked safety door switch.

Panel Sealing: Protected to IP62.

Electrical Safety:

- ? Mains equipment enclosed in fully earthed metal case.
- ? Sealed plugs and entry points on mains leads to motor and supply.
- ? All control and sensor wiring is mains isolated.

WARRANTY

Your StarLogixs PressMate Controller is guaranteed against faulty workmanship or components for a period of twelve months after the purchase date. For warranty contact your local sales agent with proof of purchase date.

This warranty does not cover damage or failure cause by or attributable to Acts of God, abuse, misuse, improper maintenance, lightning or other incidence of excessive voltage or any repairs other than those provided by an authorised StarLogixs service facility, or transportation costs.

StarLogixs is not responsible or liable for indirect, special, or consequential damages arising out of or in connection with the use or performance of the Controller or other damages with respect to any economic loss, loss of property, loss of revenues or profit, or cost of removal, installation or reinstallation.

There will be charges rendered for repairs to the product made after the expiration of the aforesaid twelve month warranty period.

* This warranty gives you specific legal rights and you may have other rights which vary from state to state.

THE HYDRAULIC PRESSURE SWITCH

The hydraulic pressure switch is pre-adjusted, and field adjustment is not recommended. The switch set-point is adjusted to be about 150psi below the hydraulic system by-pass pressure.

There are no mechanical sensors to detect the end of stroke of the main hydraulic cylinders. The Controller detects these positions by monitoring the hydraulic pressure switch state and combining this with the direction the cylinders are being driven, thus detecting end of cylinder stroke and if the cylinder is retracted or extended.

Electrically the pressure switch is normally open, and closes when the set-point pressure is applied. The electrical circuit is as below:

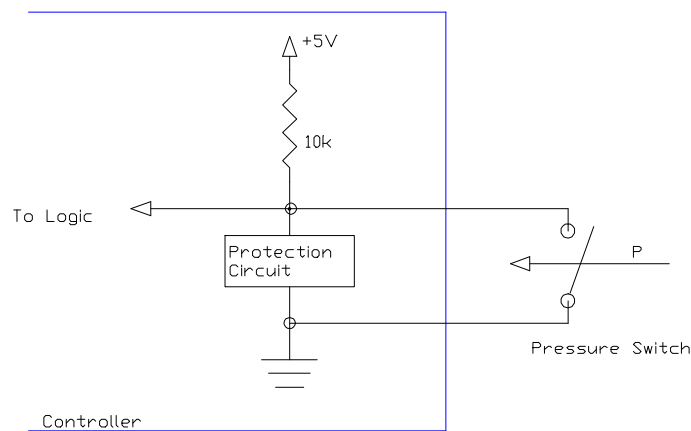

When the power is switched on the Controller loses its memory of the cylinder position, and the cylinders are always retracted when the cycle button is first pressed after the power is switched back on.

THE FULL BALE SWITCH

The full bale limit switch is situated on the front left-hand corner of the press, and detects if the left-hand cylinder is fully retracted when the pressure switch closes.

If the pressure switch closes before the cylinder fully retracts then the material in the pressing chamber is carrying the total applied load and the bale is full. It is assumed that the material under the left-hand and right-hand pressing finger sets is evenly distributed in the pressing chamber, so only one finger set is monitored by the full bale switch. The full bale switch is normally closed, with the contacts opening when the left-hand cylinder fully retracts. The electrical circuit is as below:

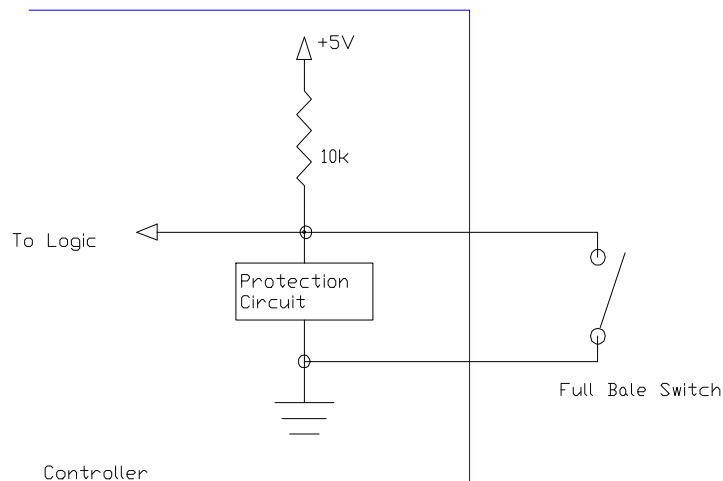

The baler is designed to complete its cycle and stop with the pressing fingers holding load onto the material in the hopper. There is sufficient internal leakage in the hydraulic system to allow the pressing fingers to creep up over time and possibly give a false full bale indication. To prevent this the Controller only monitors the full bale switch for 32 seconds after the pressing fingers stop in the down position.

When a full bale is detected a warning lamp illuminates and a beeper sounds. Also the baler will not automatically cycle if the infra-red sensor beam in the pressing hopper is blocked. However the baler will still cycle if the cycle button is pressed allowing the operator to finish-off the bale. The options plug on the Controller has a set of internal Controller relay contacts available and these change state when a full bale is detected. In some installations this feature is used to control a material feed system.

THE INFRA-RED DETECTION SYSTEM

The infra-red detection system detects material in the pressing hopper and if the Controller is active and the bale not full will cause the press to cycle until the beam is cleared (i.e. no material in pressing hopper.)

It is a transmissive type system with the IR Transmitter located on the back of the press and the receiver inside the Controller. Dirty or scratched lenses will cause the press to continually cycle.

THE HYDRAULIC VALVE ENERGISATION METHOD

The hydraulic valve coils are rated at 24V dc. All voltages on valve coils and sensors are fully mains isolated and do not constitute a shock hazard.

The electrical circuit is as below:

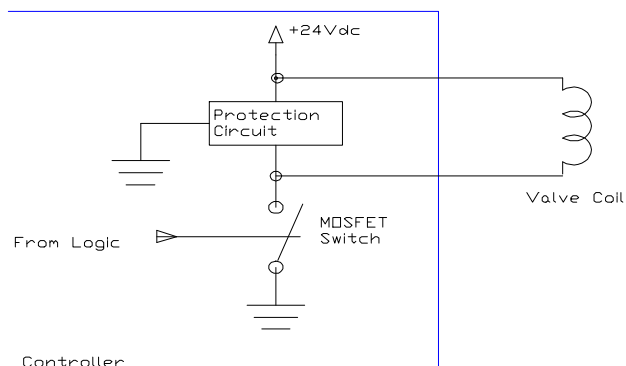

It should be noted that +24Vdc is supplied to one side of the valve coil at all times that the Controller is on. The other side of the coil will have 24V on it if the valve is off and approximately 0V if the valve is on. The +24Vdc line is normal if the voltage is between 22Vdc and 24Vdc.

MACHINE PROTECTION FEATURES IN CONTROLLER

The Controller incorporates a number of features to protect the machine from sensor faults. The two main features are:

? **Excessive Cycling**

If the infra-red detection beam becomes obstructed and cycling of the baler does not clear the obstruction, then an unattended baler may continually cycle causing unnecessary machine wear. To overcome this problem the Controller counts machine cycles and when they reach 128 cycles the Controller becomes inactive. To re-commence cycling an operator must now press the cycle button. The cycle counter is reset if the press door is opened.

? **Failed Pressure Switch**

If a pressure switch failed so that it did not close when the set-point pressure was reached, then an unattended baler could continually energise the valve coil, with the oil forced across the system by-pass valve. This would rapidly heat the hydraulic oil and cause damage. If the up or down valve coil is energised continuously for more than 64 seconds when the Controller is active, then an internal fault flag is set and the Controller becomes inactive. To recommence operation the operator must press the cycle button, and the fault will now be observed. If no action is taken to repair the fault the press will again shut down after 64 seconds.

DOOR SAFETY SWITCHES

The Controller is fitted with two door safety switches. The OMRON D4DS-1SFS switch can only be activated by its D4DS-K1 Key, which is fixed to a mechanism on the top door. Either opening the top door or pressing the Emergency Bar will withdraw the key from the switch. Also fitted to the side of the Controller is an OMRON Z15GQ22B limit switch which is closed by a striker plate fixed to the top door.

The two switches operate on completely separate circuits in the Controller and both must be closed for the Controller to sense that the top door is shut. This provides a fully redundant safety back-up switching system. A door open condition is indicated by illumination of the DOOR LED on the Controller.

THE CONTROLLER ACTIVE LED

The second LED from the top on the Controller is the active LED. This indicates if the Controller is in full automatic mode. If the LED is flashing the Controller will start the electric motor and cycle the press if the infra-red detection beam is interrupted. For safety reasons the Controller is always inactive when the power is switched on, when the press doors are open and after the doors are shut. Pressing the emergency bar halts press operation and also forces it to the inactive state. To enter the active state the press doors must be shut, emergency bar released and the operator must press (and hold for approximately 0.5 seconds) the cycle button.

ELECTRIC MOTOR CONTROL

The Controller co-ordinates the electric motor function. If the motor has stopped and some press action is required, then the motor is started but all hydraulic valve drive signals are suspended for approximately 4 seconds to allow the motor to stabilise at its operating speed under no mechanical load. Further press actions while the motor is running do not incur the 4 second delay.

At the completion of press actions the motor runs for a further 16 to 20 seconds. This avoids rapidly stopping and starting of the motor when brief interruptions in press actions occur.

OPTIONS PLUG LOOP-BACK

The Controller options socket has a plug fitted which contains a loop-back connection across the auxiliary door switch pins. The door open LED will remain on and most press functions will be disabled if the options plug is removed.

The Controller options socket provides a means for connecting an optional remote control kit or auxiliary control kit as mentioned in the owners manual section of this document.

TROUBLE-SHOOTING

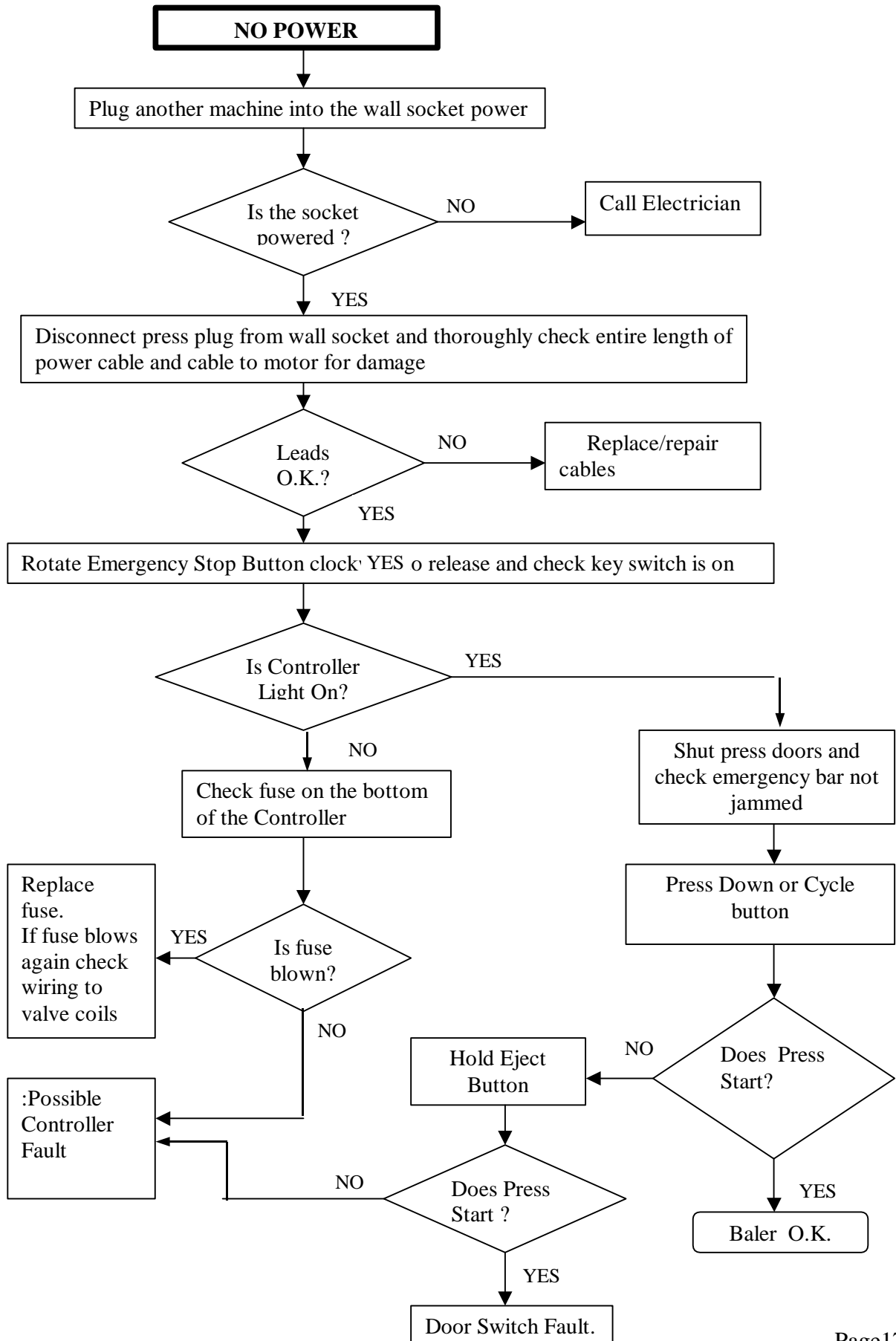

TROUBLE-SHOOTING

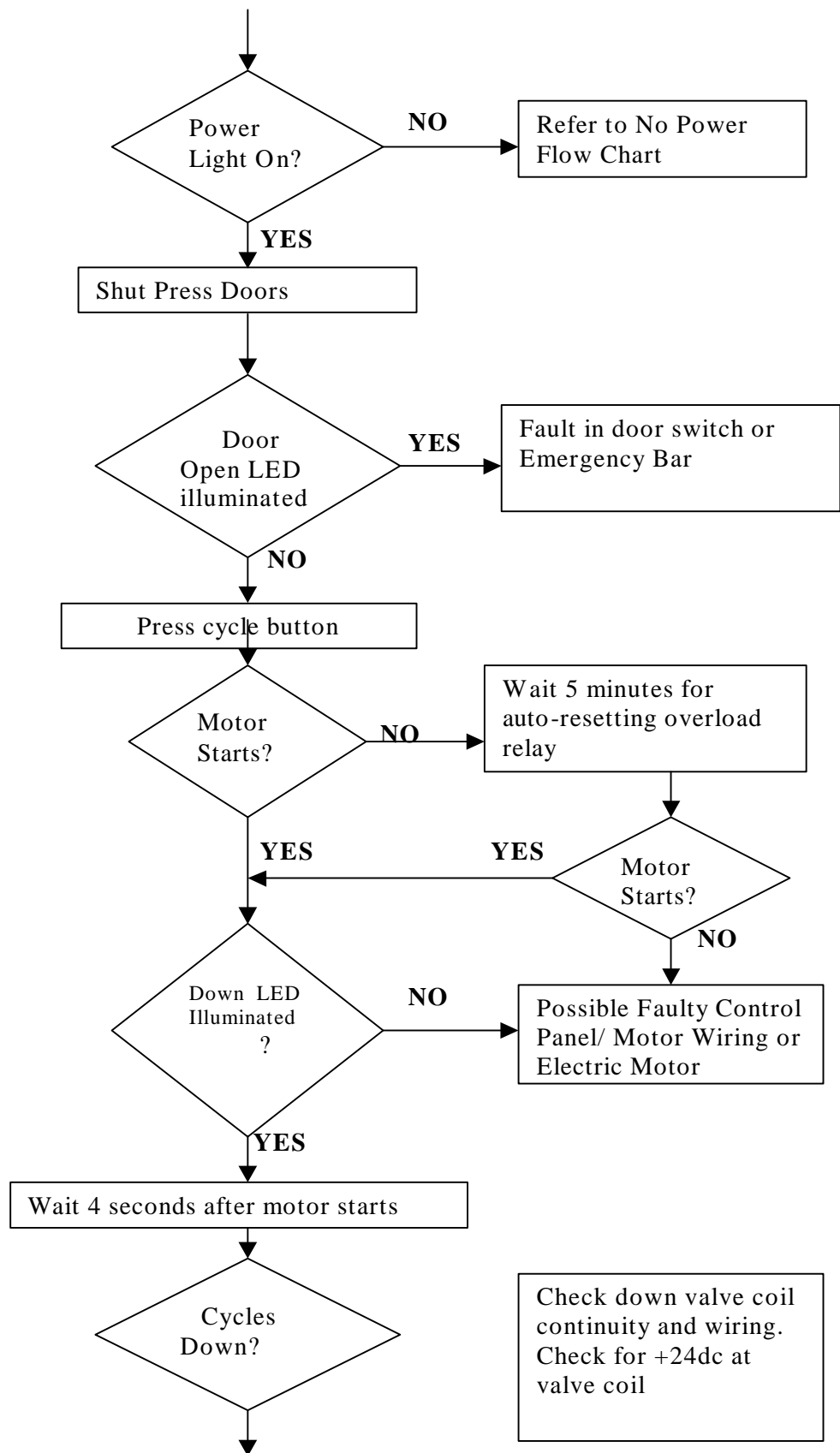

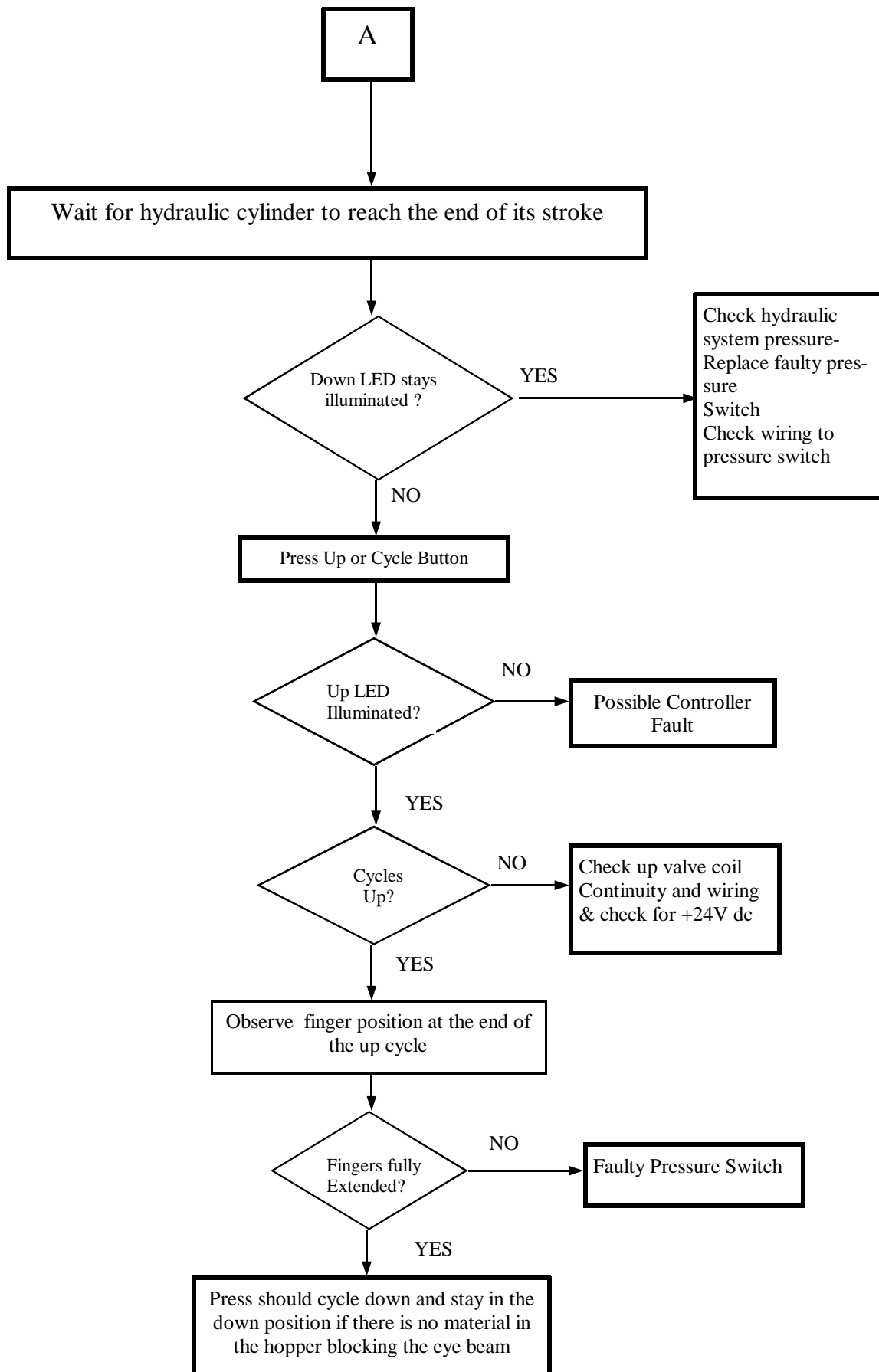

TROUBLE-SHOOTING

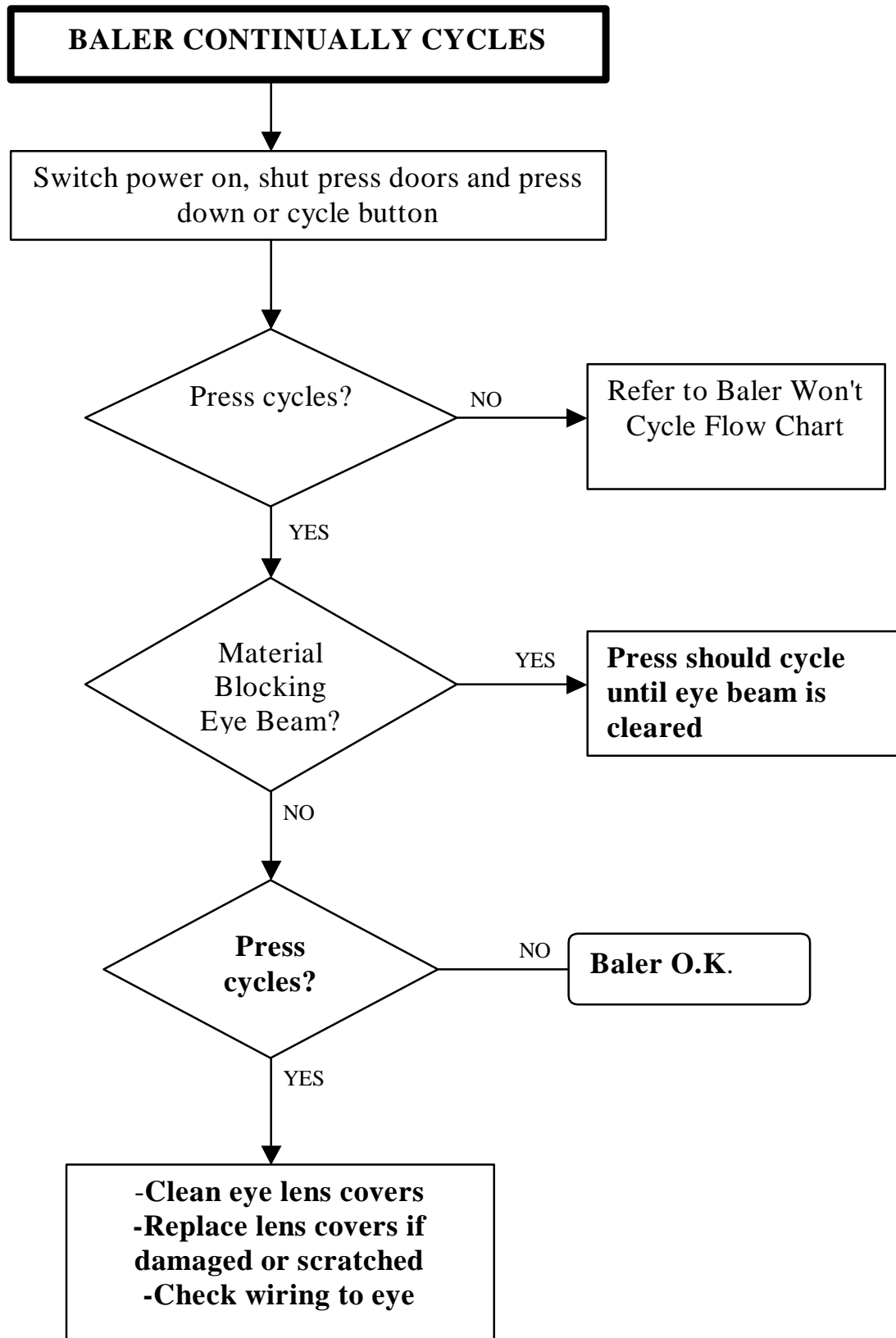

TROUBLE-SHOOTING

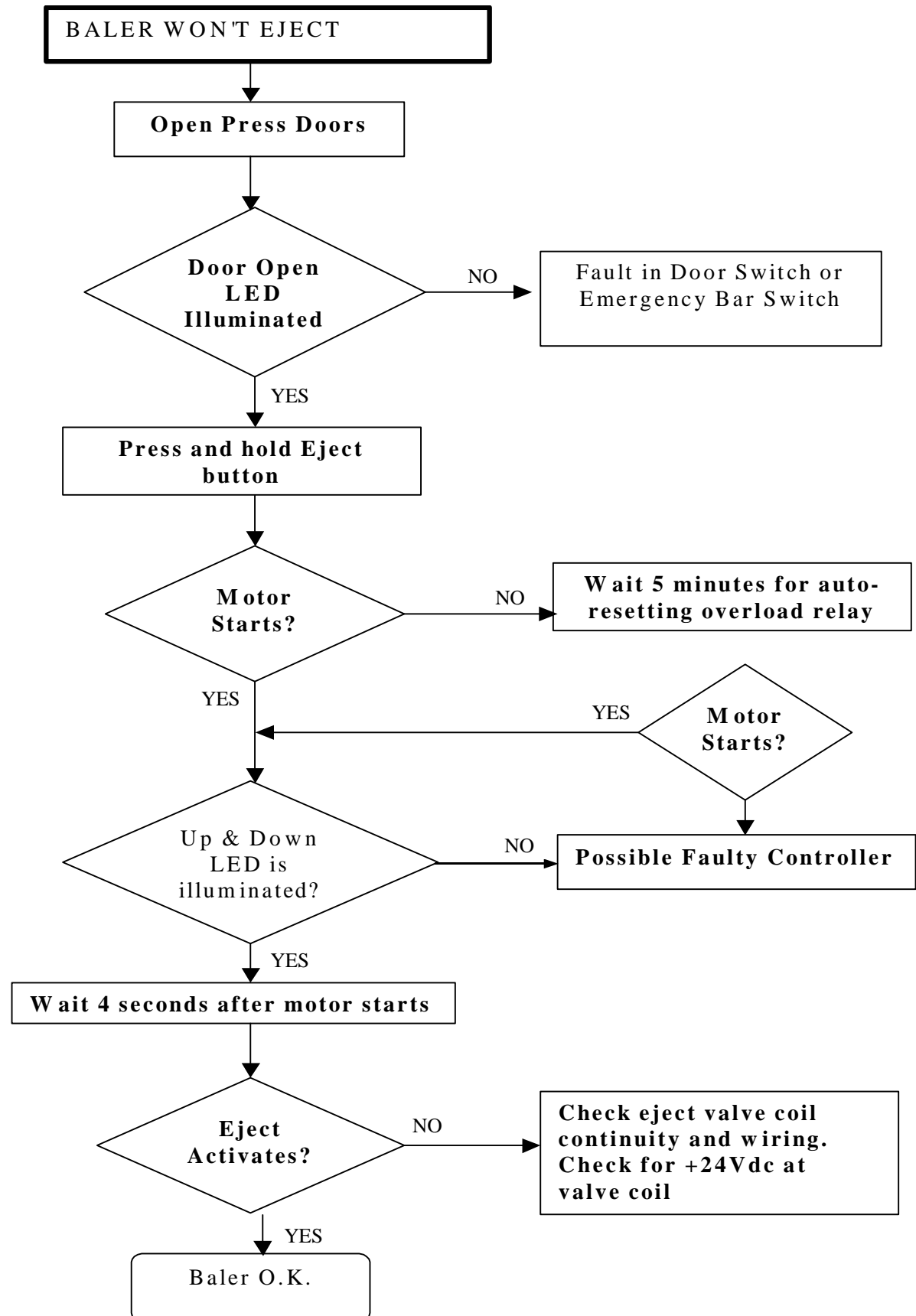

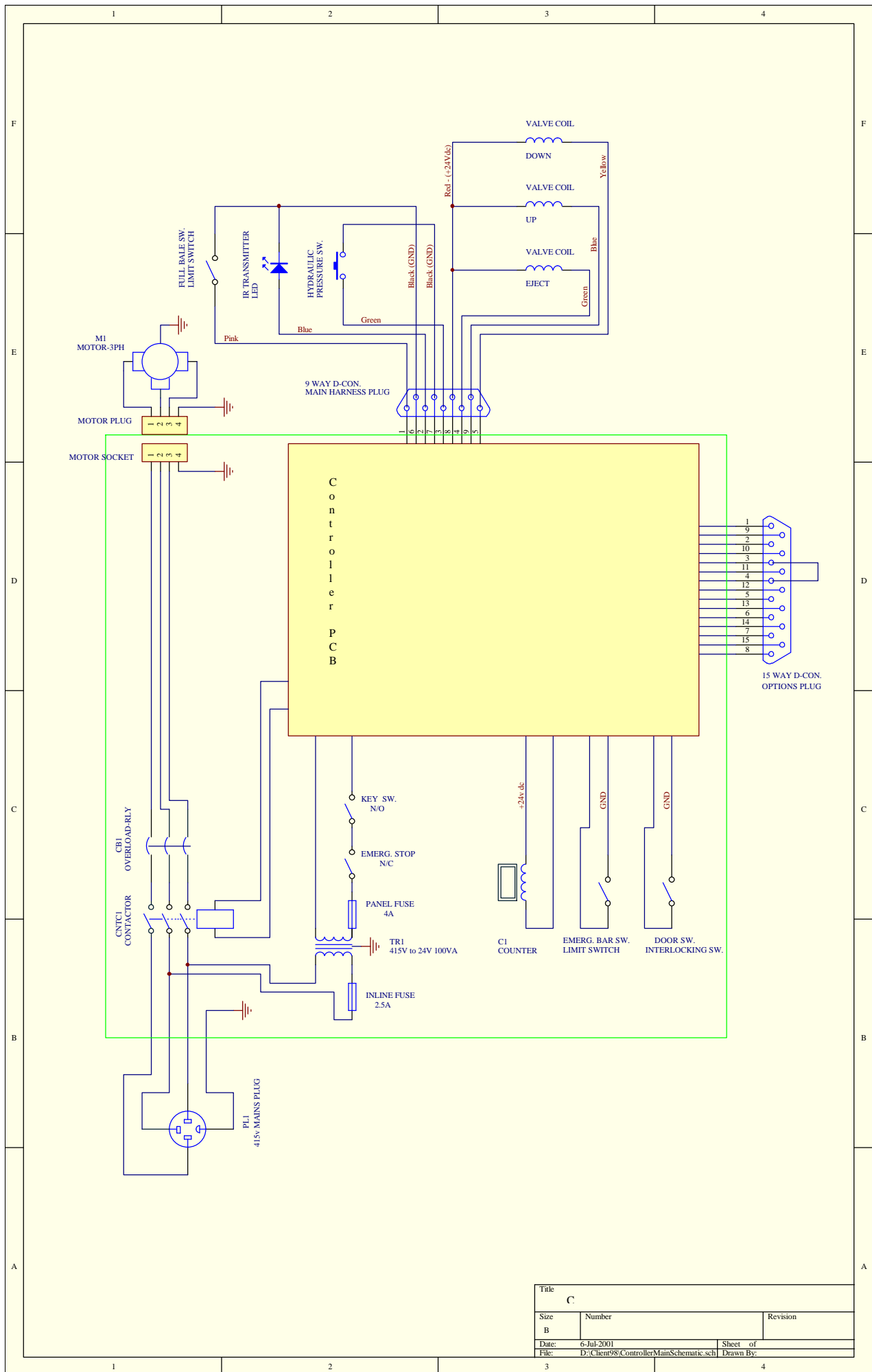

Title		
C		
Size	Number	Revision
B		
Date:	6-Jul-2001	Sheet of
File:	D:\Client98\ControlMainSchematic.sch	Drawn By:

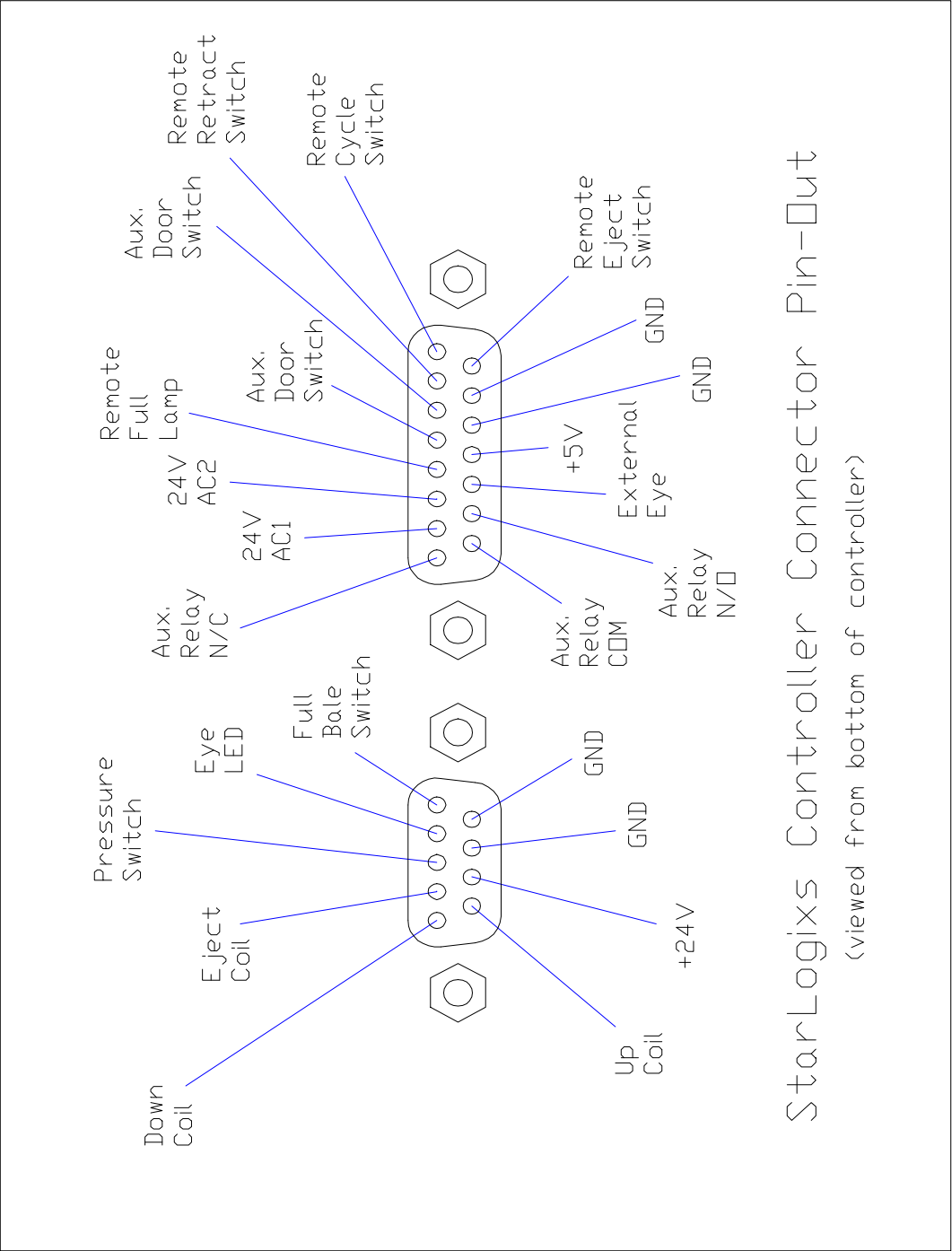

StarLogixs Controller Connector Pin-Out

(viewed from bottom of controller)

MOTOR CONTACTOR AND OVERLOAD RELAY DETAILS

All contactors and overloaders are General Electric Brand, and the parts numbers are listed below for the range of Controller models:

? **2.2 kW Single Phase 240V**

Full load Amps = 17

Overload Relay = RTIM (5.5 to 8.5A)

Contactor = CL00A310T—24Vac coil

Note: all three phases in parallel—only active switched.

? **2.2kW Three Phase 415V**

Full Load Amps = 4.8

Overload Relay = RTIL (4 to 6.3A)

Contactor = CL00A310T—24Vac coil

? **4kW Three Phase 415V**

Full Load Amps = 8

Overload Relay = RTIN (8.0 to 12A)

Contactor = CL00A310T - 24Vac coil

? **5.5kW Three Phase 415V**

Full Load Amps = 11

Overload Relay = RTIP (10 to 16A)

Contactor = CL01A310T –24Vac coil

SPARE PARTS LIST

Description	StarLogixs No.	Manufacturer	Man. Part Number
Full Bale Switch	SL-S008	Omron	Z15GQ21-B
Emergency Stop	SL-S001	General Electric	P9CER4RN
Key Switch	SL-S009	General Electric	P9XSCD0A95
Spare Keys	SL-H026	General Electric	077C3095
Interlocked Door Sw.	SL-S006	Omron	D4DS-15FS
Interlocked Sw. Key	SL-S005	Omron	D4DS-K1
N/C Contact (E.Stop)	SL-S002	General Electric	P9B01VN
N/O Contact (Key Sw.)	SL-S003	General Electric	P9B10VN
Panel Counter (small clear type)	SL-H016	RS Components	331-360
Mains Plug (3 phase)	SL-W1003	Australec	IS56420
Mains Cable (3 phase)	SL-W1004	Haymans	ELCF4015
Piezo Buzzer	SL-M011	WES(Kingstate)	KPE657
Full Bale Lamp	SL-H001	Electrical Specialists	128-85890
Full Lamp Bulbs (24V 3W)	SL-H002	Electrical Specialists	47268
Panel Fuse (4A 32mm Glass)	SL-M018	WES	MGC4A
Wiring Harness	SL-W1001	StarLogixs	
2.2kW Overload Relay	SL-S010	General Electric	RT1L
4kW Contactor (with 24V ac coil)	SL-U002	General Electric	CL00A310T
4kW Overload Relay	SL-S011	General Electric	RT1N
5.5kW Contactor (with 24V ac coil)	SL-U003	General Electric	CL01A310T
5.5kW Overload Relay	SL-S012	General Electric	RT1P
Bulkhead Box (eye transmitter cover)	SL-H0010	Electus	HB6075
Eye Transmitter Assem.	SL-SC001-EYE	StarLogixs	
Thermal Switch Assem.	SL-SC003-TS-5.5	StarLogixs	
Red Perspex eye cover	SL-H015	StarLogixs	
Clear Perspex eye cover	SL-H020	StarLogixs	

OLDER STYLE BALERS

Key Switch	SL-H028	Farnell	263-353
Eye Receiver PCB	SL-SC005	StarLogixs	
Panel Counter (large black type)	SL-H027	Farnell	233-286
Emergency Bar Switch		Omron	Z15GQ22-B

Distributors List

General Electric Distributors

Bell Electrical

NSW

1-5 Carter Street
Homebush Bay 2127

Phone: (02) 9364 1700

Fax: (02) 9364 1739

Melbourne

140 Burwood Hwy
Burwood 3125

Phone: (03) 9888 8100

Fax: (03) 9888 0280

Brisbane

42-44 Manilla Street
East Brisbane. 4169

Phone: (07) 3391 8311

Fax: (07) 3891 5603

Adelaide

80 George Street
Thebarton. 5031

Phone: (08) 8354 0588

Fax: (08) 8352 7755

Perth

40 Hargreaves Street
Belmont. 6104

Phone: (08) 9479 4766

Fax: (08) 9479 4884

Electrical Specialist

4/35 Radley Street
Virginia. QLD 4014

Phone: (07) 3265-1788

Fax: (07) 3865-1875

Ormon Distributors

NSW

Automation Systems Pty Ltd
Unit 1, 21-25 Silverwater Road,
Silverwater NSW 2141

Phone: (02) 9748 7811

Fax: (02) 9748 7644

DGE Systems Pty Ltd
103 Broadmeadow Road,
Broadmeadow NSW 2292

Phone: (02) 4961 3311

Fax: (02) 4969 5067

Newcastle

Colterlec Pty Ltd
8 Rosegum Close,
Warabrook NSW 2304

Phone: (02) 4960 0077

Fax: (02) 4960 0088

Melbourne VIC

Automation Systems
Unit 1/87 Heatherdale Road,
Ringwood VIC 3134

Phone: (03) 9874 0888

Fax: (03) 9874 6677

Geelong

Factory Controls
65 Douro Street
North Geelong VIC 3215

Phone: (03) 5278 8222

Fax: (03) 5278 9761

Brisbane QLD

Control Logic
34 Thompson Street
Bowen Hills QLD 4006

Phone: (07) 3252 9611

Fax: (07) 3252 8776

Townsville

Control Logic
4/24 Leyland Street
Garbutt QLD 4814

Phone: (07) 4728 6009

Fax: (07) 4775 7446

Gladstone

Control Logic
28 Beckinsale Street
Gladstone. QLD 4680

Phone (07) 4972 8411

Fax: (07) 4972 6796

SA

Adelaide
Pacific Datacom
3 Deacon Avenue,
Richmond. SA. 5033

Phone: (08) 8443 6288

Fax: (08) 8443 6822

WA Perth

Techsource
182 Rutland Avenue,
Carlisle. WA. 6101

Phone: (08) 9472 1999

Fax: (08) 9472 3838

Farnell

72 Ferndell Street
Chester Hill. NSW 2162

Phone: 1300 361 005

Fax: 1300 361 225

RS Components

NSW

25 Pavesi Street

Phone: 1300 656 636

Smithfield NSW 2164

Phone: (02) 9681 8588

Fax: (02) 9681 8599

QLD

250 Beatty Road

Phone: 1300 656 636

Archerfield QLD 4108

Melbourne

Phone: 1300 656 636

294 Salmon Street

Port Melbourne. VIC 3207

Perth

Phone: 1300 656 636

26 Walters Drive

Osbourne Park. WA 6107

Phone: 1300 656 636

Electus

100 Silverwater Road

Phone: 1300 738 355

Silverwater. N.S.W. B.C. 1811

Fax: 1300 738 500

Procedure to Change Power Block

[Disconnect from power source and completely remove Controller from press]

1. Remove 3 Phase plug from the end of the supply cable. Take note of any cable clamps and wire locations and ensure they are returned to original when re-fitting the plug.

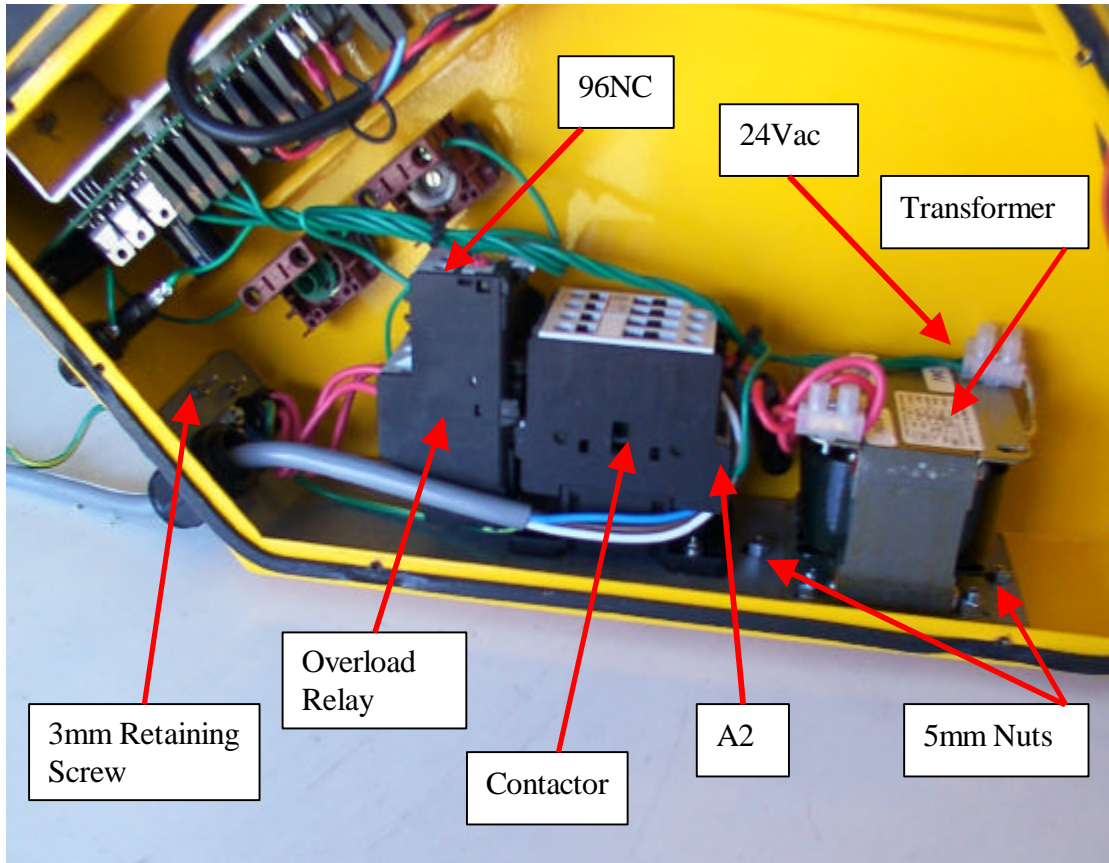

2. Remove back cover from Controller.
3. Using an 8mm ring spanner remove the two 5mm nuts adjacent to the transformer. **Note:** These two nuts are **not** the ones holding the transformer.
4. Remove the 3mm retaining screw.
5. Loosen the screw marked 96NC on the top of the overload relay, and remove the wire.

6. Loosen the screw marked A2 on the contactor and remove wire.
7. Loosen the screws in the contact block on the top of the transformer marked 24V. Remove the two wires. **Note:** That it does not matter which way around these two wires are connected.
8. Remove the power block unit from the control panel.

DO NOT REMOVE THE 415V SUPPLY CABLE OR ANY OF THE 415V WIRING. ALL OF THE ABOVE MENTIONED WIRES ARE AT LOW VOLTAGE AND MAINS ISOLATED.

9. Fit new power block into the unit and reverse the above procedures for fitting. Ensure that wires are properly clamped and adequately tightened. If any zip ties were cut to free wires ensure they are replaced. Finally ensure mounting bolts are adequately tightened.

NOTE: BECAUSE THE POWER BLOCK HAS LETHAL VOLTAGES PRESENT DURING OPERATION ATTENTION TO DETAIL IN FITTING THE NEW UNIT IS IMPORTANT TO ENSURE ON-GOING SAFETY.

DO NOT FORGET TO FIT EARTH WIRE TO PRESS BODY WHEN RE-FITTING THE CONTROLLER.

Procedure for Changing the Interlocked Door Switch

[Disconnect Power Source and completely remove Controller from the press]

1. Remove back cover from Controller.
2. Open cover on D4DS-15FS door switch and remove two screws securing the two wires.
3. Cut zip tie around gland nut on the bottom of the switch. Loosen gland nut and remove wiring from switch.
4. Remove two 4mm bolts securing door switch to the panel. Note the position of washers.
5. Carefully lift switch off plastic rivet. Do not disturb or attempt to remove rivet.

6. If necessary remove 4 screws on the top of the NEW switch and rotate the head to the correct orientation. Replace screws.
7. Remove gland nut from OLD switch and fit to the NEW switch.
8. Carefully fit blind hold in NEW switch over the plastic rivet.
9. Complete process by performing steps 1 to 4 in reverse order. Ensure zip ties are re-fitted.

NOTE: It doesn't matter which way around the wires are fitted, but make sure the ring terminals don't short onto the two lower switch terminal screws.

Procedure to Change the PCB

[Disconnect from power source and completely remove Controller from press]

1. Remove rear cover plate from Controller.
2. Label each wire connected to the printed circuit board (PCB). One method is to paint a small section of the connector insulation boot with liquid paper and then number with a pen or pencil. Start with 1 on the lower connector and mark in increasing order. Remove all wires from PCB.

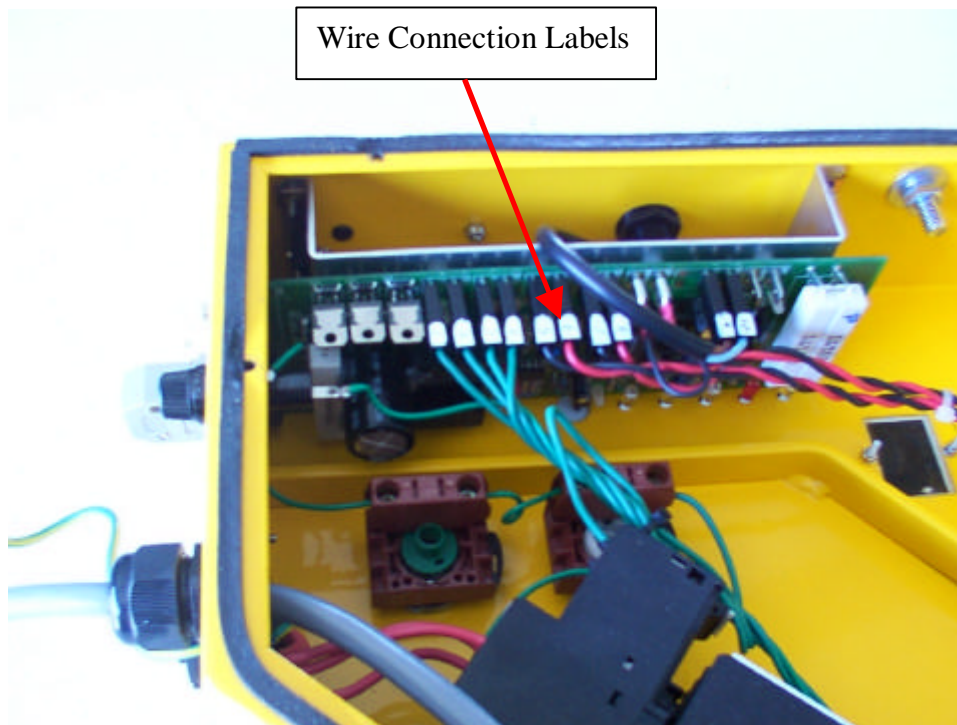

3. Loosen the two screws and remove the options plug.
4. Using a 5mm nut driver remove the 4 D-connector nuts.
5. Using a 1 point Phillips screw-driver remove the 4 PCB retaining screws.

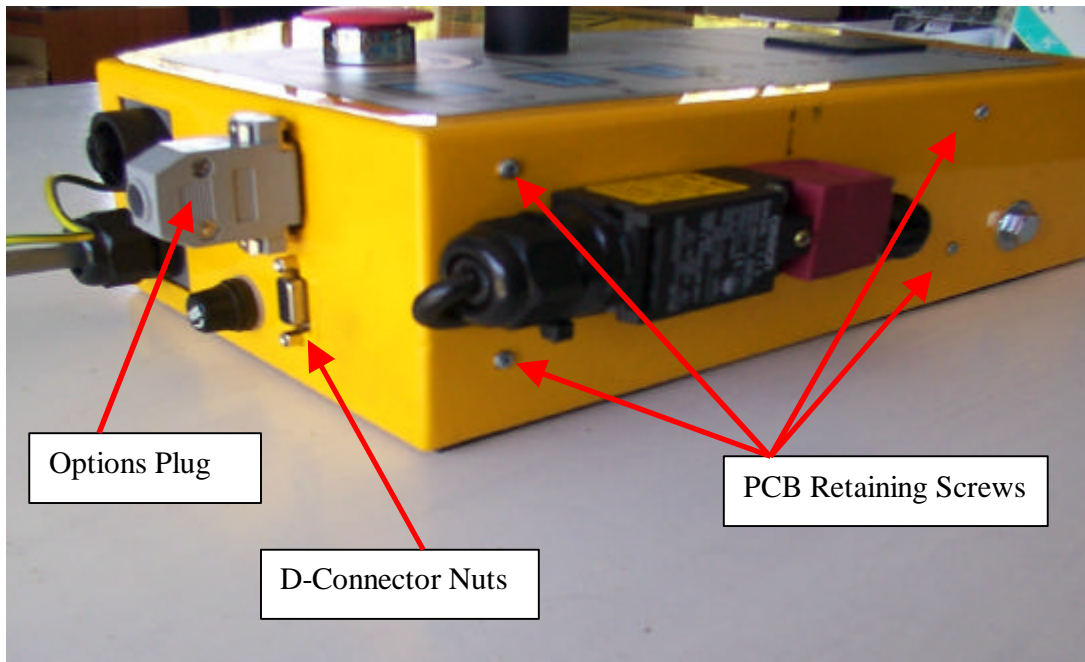

6. Remove PCB from Controller.
7. Fit new PCB by reversing above steps.

IMPORTANT NOTES

1. The LED's can be slightly bent so they align with the windows in the front panel.
2. All PCB retaining screws and D-connector nuts fit through slotted holes in the panel metalwork. This allows adjustment of the PCB position so as to allow correct operation of the touch pad. Each touch pad should provide a positive "click" without deforming the plastic touch pad into the hole in the metal panel. Also the tactile switches mounted on the PCB should slightly deform the touch pad into an outward bump. This should be detected by lightly running your finger across the surface of the touch pad. Do not excessively deform the touch pad outwards. (about 0.2mm)
3. The D-connector nuts are brass and excessive tightening will snap them.

SET-UP OF TACTILE SWITCHES IN RELATION TO THE TOUCH PAD

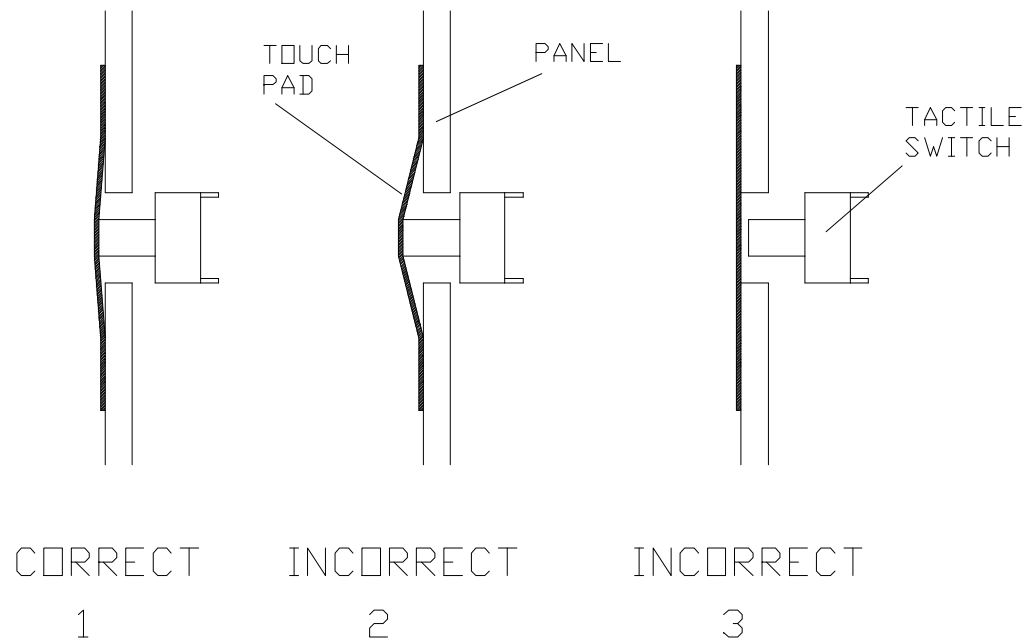

NOTE: IT IS VERY IMPORTANT TO CORRECTLY SET THE TACTILE SWITCH POSITION. IN POSITION 2 THE SWITCH PROTRUDES TOO FAR THROUGH THE PANEL, EXCESSIVELY DEFORMING THE TOUCH PAD AND ALLOWING THE OPERATOR TO OVERLOAD THE SWITCH IF IT IS PRESSED WITH FORCE. IN POSITION 3 THE SWITCH DOES NOT PROTRUDE SUFFICIENTLY CAUSING THE TOUCH PAD TO BE DEFORMED INTO THE PANEL HOLE, ULTIMATELY FRACTURING THE TOUCH PAD. POSITION 1 IS CORRECT WITH ABOUT 0.5mm DEFORMATION IN THE TOUCH PAD. THE TACTILE SWITCH TRAVEL IS ONLY ABOUT 0.4mm.



27 Young Street
DEEPWATER. N.S.W. 2371
Phone: (02) 67345 262
Fax: (02) 67345 020
Email: mark@starlogixs.com.au
A.C.N.: 095 551 198

24th September 2003

PRESSMATE CONTROLLER CHANGES
TO SATISFY REQUIREMENTS OF AS4024.1:1996
CATEGORY III SAFETY

The following modifications were carried out :

- 1) A PILZ PNOZ X2.1 safety relay was fitted to monitor both contacts of the door switch. Loss of safe condition causes the relay contacts to open isolating the current drive to the hydraulic valve coils that drive the pressing fingers up or down.
- 2) An OMRON D4DS-1AFS interlocked door switch was used which has two N/C contacts. This switch positively drives the contacts open.
- 3) The latching type emergency stop button was fitted with an extra contact that isolates the +24Vdc supply to the safety relay causing the relay contacts to open when the emergency stop is pressed. The other contact in the emergency stop isolates all power to the control part of the circuit including the supply voltage for the hydraulic valve coil drivers.
- 4) Previously the controller would cause the electric motor powering the hydraulic pump to run-on for 20seconds after the completion of any press function, thus minimizing the number of motor starts. This function has been changed so the motor only runs-on when the press top door is shut. If the top door is opened the motor will immediately stop. The only function that will start the motor with the top door open is eject, and when the eject button is released the motor immediately stops. This minimizes the consequences of a jammed spool in one of the hydraulic valves. Note that the eject has a dead-man type function where the eject valve and the motor are only powered while the eject button is held.

Details of these modifications are provided in the following pages :

CAT III SAFETY—WIRING DIAGRAM

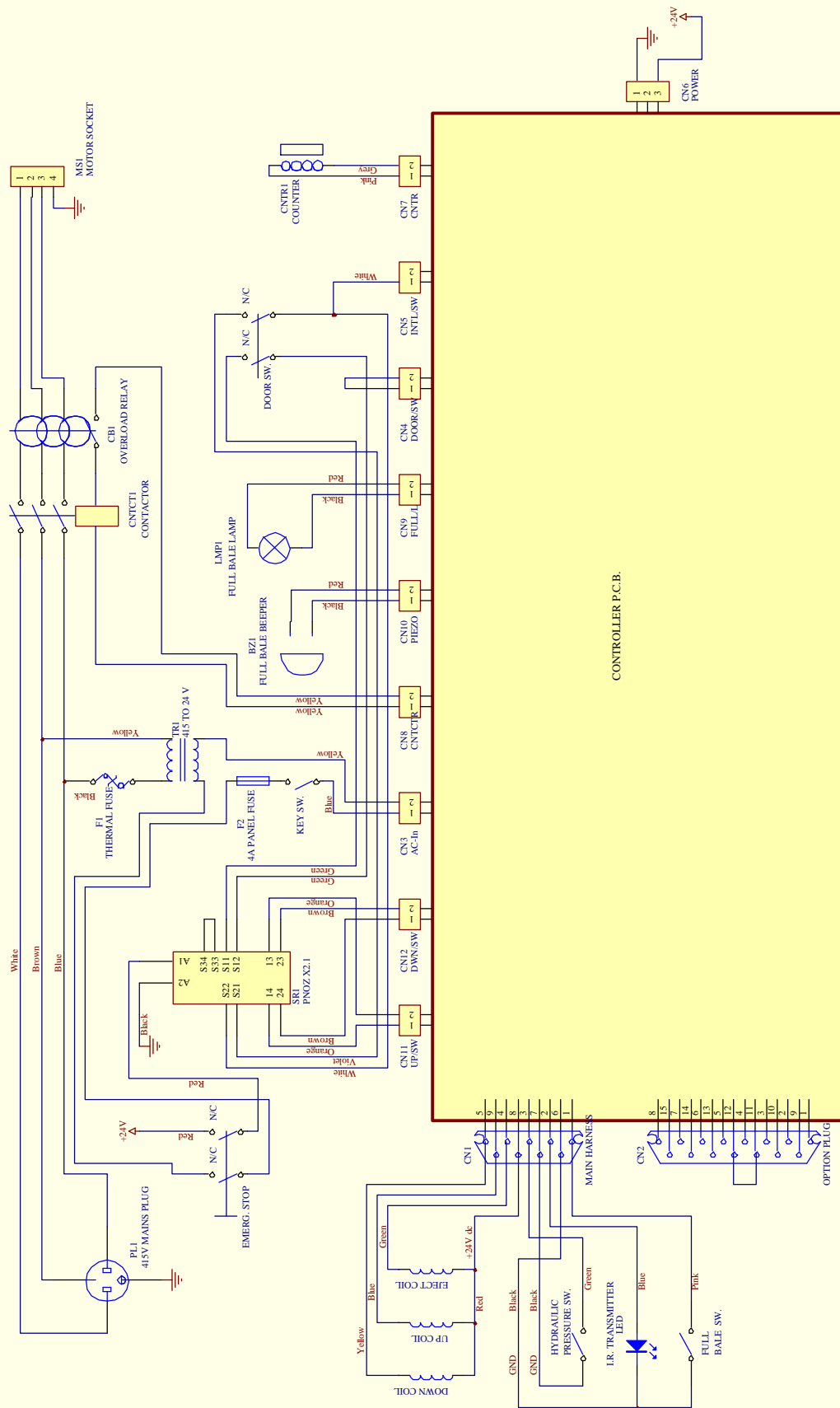

Title	S				
Size	1	Number		Revision	
B					
Date:	05 Sep 2003	Sheet of			6
File:	g:\D:\Controller\Panel\Wiring.sch	Drawn By:			

CRITICAL SAFETY COMPONENTS

Substitution of other parts may void the safety compliance of this machine.

Item/Circuit Designation	Manufacturer	Type/Model	Technical Data	Conformity with following standards	3 rd party marks of approval
Door Switch	Omron	D4DS-1AFS	400Vac 2A contact rating – positively driven contacts	EN1088, EN50047, EN60947-5-1, GS-ET-15, UL508, CSA C22.2	CE and UL
NC Contact Block (on Emergency Stop)	General Electric	P9B01VN	10A contact rating	IEC 947-5-1, VDE 0660	CE and UL
Emergency Stop	General Electric	P9CER4RN	High strength metal body – latching type	EN 50007, IEC 529	CE and UL
SR1 Safety Relay	PILZ	PNOZ X2.1	24Vdc	EN 50081-1, 01/92, EN 50082-2, 03/95, IEC 60068-2-3, VDE 0113, EN 6024-1	BG, UL and CSA
Door Switch Key	Omron	D4DS-K1			



STARLOGIXS PTY. LTD.
27 Young Street
DEEPWATER. N.S.W. 2371
www.starlogixs.com.au